

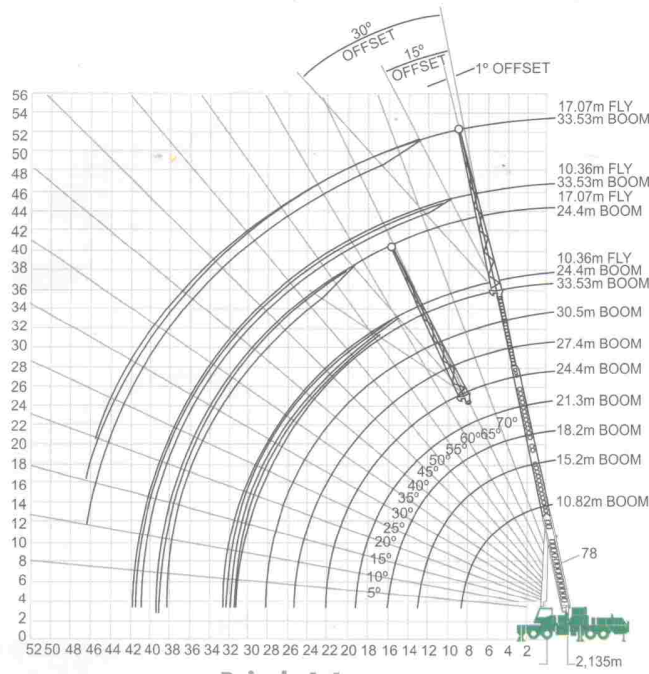

Tels.: 4476.1924 /4479.6751/4472.8177

**- HTC-8665 - Link-Belt**

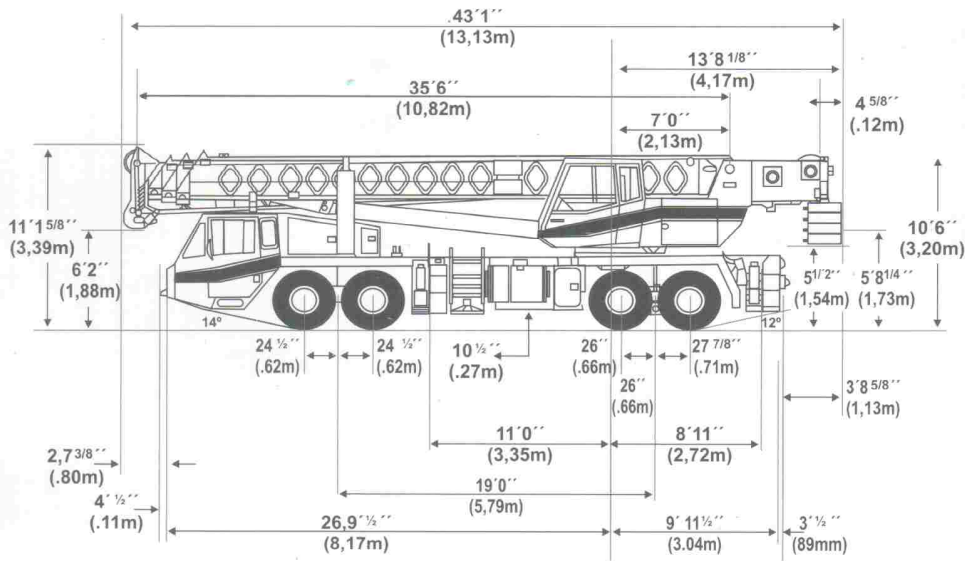

Load Radius In Meters	10,82m to 18,30m Main Boom						Load Radius In Meters			
	10,82m		15,2m		18,3m					
	Loaded Boom Angle (Deg.)	Over Rear	Loaded Boom Angle (Deg.)	Over Rear	Loaded Boom Angle (Deg.)	Over Rear				
3,0	66.0	60.000	60.000	73.5	34.100	34.100	3,0			
3,5	63.0	51.700	51.700	71.5	34.100	34.100	3,5			
4,0	60.0	47.600	47.600	69.5	34.100	34.100	4,0			
4,5	56.5	43.950	43.950	67.5	34.100	34.100	4,5			
5,0	53.0	40.800	40.800	65.5	34.100	34.100	5,0			
6,0	45.5	34.450	34.450	61.0	34.100	34.100	6,0			
7,0	37.0	28.950	28.950	56.5	28.900	28.900	7,0			
8,0	25.0	23.050	23.050	51.5	23.100	23.100	8,0			
9,0	See Operation Note 2.0		46.0	18.800	18.800	55.5	18.800	9,0		
10,0			40.5	15.700	15.700	51.5	15.700	10,0		
12,0			25.0	11.500	11.500	72.5	11.550	11.550	12,0	
14,0						31.0	8.800	8.800	14,0	
16,0						11.0	6.900	6.900	16,0	
Min. Boom Angle/ Cap.			0°	13.300	13.300	0°	7.350	7.350	0°	5.200

Load Radius In Meters	10,82m to 18,30m Main Boom						Load Radius In Meters
	21,3m		24,4m		Load Radius In Meters		
	Loaded Boom Angle (Deg.)	Over Rear	Loaded Boom Angle (Deg.)	Over Rear			
4,0	76.0	25.400	25.400			4,0	
4,5	75.0	24.100	24.100	77.0	19.500	4,5	
5,0	73.5	22.950	22.950	76.0	18.700	5,0	
6,0	70.5	20.750	20.750	73.5	17.150	6,0	
7,0	67.5	19.000	19.000	71.0	15.570	7,0	
8,0	64.5	17.500	17.500	68.5	14.400	8,0	
9,0	61.5	16.200	16.200	66.0	13.350	9,0	
10,0	58.5	14.950	14.950	63.5	12.450	10,0	
12,0	51.5	11.500	11.500	58.0	10.850	12,0	
14,0	43.5	8.800	8.800	51.5	8.800	14,0	
16,0	34.5	6.900	6.900	45.0	6.900	16,0	
18,0	22.0	5.500	5.500	37.5	5.500	18,0	
20,0				27.5	4.450	20,0	
22,0				11.5	3.600	22,0	
Min. Boom Angle/ Cap.	0°	3.800	3.800	0°	2.800	2.800	Min. Boom Angle/ Cap.

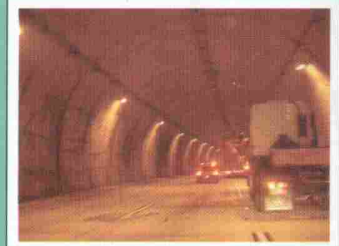
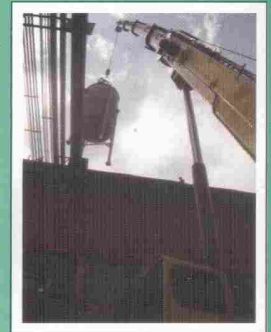

**Remoção Especial**



**Transporte**



**Guindaste**

